

**35SI HP™ & 36SI HP™ ALTERNATOR INSTRUCTIONS FOR REPLACING
DELCO REMY 21SI, 22SI, 23SI, 33SI, 34SI, 35SI AND 36SI ALTERNATORS**

When upgrading one of the above Alternators to a 35SI HP™ or 36SI HP™, the Delco Remy 35SI HP or 36SI HP with Remote Sense™ Technology is strongly recommended. The remote sense™ option, also available on 21SI, 22SI, 33SI and 34SI is highly recommended for improved Battery Monitoring and Charging for all applications. **Remote Sense™ Technology** senses the voltage level at the batteries or similar location where battery system voltage can be read and adjusts alternator output accordingly. A direct connection from the alternator's remote sense terminal to the batteries provides highly accurate system voltage readings and optimizes state of charge.

Typical Alternator Battery Charge Circuit without a Remote Sense™ line is only **14.0 volts**, with normal voltage drops in the circuit.

Alternator Battery Charge Circuit with a Remote Sense™ line is **14.5 volts**. Voltage is always adjusted to battery system requirements.

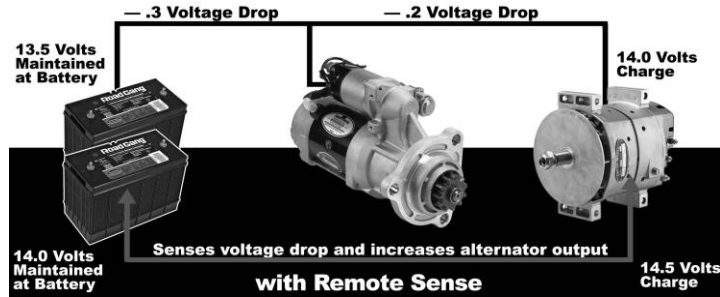

14.5 Alternator Volts
- .2 Voltage Drop
- .3 Voltage Drop
14.0 Volts Sensed at Alternator
+ .5 Voltage Adjustment with Sense Line
14.5 Charge Voltage

There are two types of remote sense circuits in Delco Remy alternators. One type has remote sense with an internal back-up circuit and the other type does not have an internal back up circuit.

The 35SI HP™ and 36SI HP™ all have internal back-up circuits. If the sense line is not connected to the remote sense™ terminal, the alternators regulate at a voltage above the external sense setting to compensate for any voltage drop between the alternator output terminal and the batteries.

WARNING!!! ALWAYS USE PROPER EYE PROTECTION WHEN PERFORMING ANY MECHANICAL REPAIRS TO A VEHICLE – INCLUDING, BUT NOT LIMITED TO, ANY INSTALLATION AND OR REPAIRS TO THE DELCO REMY ALTERNATORS. FAILURE TO USE PROPER EYE PROTECTION CAN LEAD TO SERIOUS AND PERMANENT EYE DAMAGE.

DANGER!!! To avoid injury or damage, always disconnect the negative cable at the battery before removing or replacing the alternator. The alternator output terminal is always live (“hot”). If the battery is not disconnected, a tool accidentally touching this terminal and ground can quickly get hot enough to burn skin or damage to the tools and surrounding parts.

FOLLOW ENGINE OR VEHICLE MANUFACTURER’S INSTRUCTIONS FOR REMOVING THE OLD ALTERNATOR FROM THE ENGINE AND INSTALLING THE NEW ALTERNATOR.

PULLEY INSTRUCTIONS: Use pulley from old alternator if this alternator does not have a pulley or pulley supplied is different from the one on alternator being replaced. **NOTICE!** When changing the pulley, keep the alternator in the horizontal position and do not apply any pressure to end of the shaft. Internal damage will occur if the shaft is pushed back and turned. If there were spacers, when the fan and pulley were removed, make sure all spacers are replaced when installing the fan and pulley on the 35SI or 36SI alternator. Hold the shaft by placing an 8 mm (5/16”) hex wrench in the hexagonal hole in the shaft while removing or installing the pulley. **Tighten the pulley nut to 95-108 Nm (70-80 lb ft).**

BELT TENSIONING INSTRUCTIONS: Improper belt tension can cause premature alternator failure. If the belt must be tightened manually, place a wood block between the alternator and pry bar (See illustration). Pry as close to the center of the unit as possible. Use a torque wrench to tighten mounting bolts to specified torque. Follow vehicle or engine manufacturer’s specifications carefully for belt tension and mounting bolts torque. **DO NOT OVER TIGHTEN BELT!**

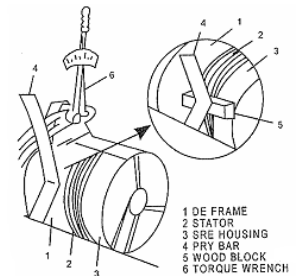

INSTALLATION INSTRUCTIONS (See illustrations, page 2): When removing or installing alternator hardware, hold the bottom jam nut with a wrench to prevent loosening the terminals from the alternator.

- ◆ Disconnect the negative (-) cable at the batteries.
- ◆ Identify all leads when removing the old Alternator and install them on the same terminals of the 35SI or 36SI Alternator.
- ◆ Some 21SI and 22SI applications may require enlarging the ring terminals. Others will require cutting and terminating wiring for one or all of the “I”, “R” and “Remote Sense” leads.
- ◆ **Cut lead, strip insulation 1/2”, insert wire into an A3 Amp or equivalent ring terminal, crimp and solder the wire.**
- ◆ **NOTICE!** Ensure all leads are hooked back up or contained where they can not ground. The sense lead is live “hot”.
- ◆ **Torque all fasteners to values labeled on the illustration** (page 2).

This 35SI or 36SI may have more terminals than the alternator it is replacing had or used. This 35SI or 36SI will function properly by only connecting the leads that were used on the alternator being replaced.

NOTICE - Only licensed Remy International, Inc. product and component parts should be used, and the use of other parts or modifications not approved by Remy International, Inc. will void all applicable warranties. The failure to carefully follow these Installation Instructions, set forth above, will void all applicable warranties. DELCO REMY is a registered trademark of General Motors Corporation, licensed to Remy International, Inc. Pendleton, IN 46064.

TERMINAL DESCRIPTIONS (See illustrations):

“POS” Terminal - Output terminal connects to the Positive (+) Battery terminal.

“R” Terminal - Relay terminal carries half systems voltage and may be used for certain types of control relays, charge indicators, tachometers or similar devices. The current draw should not exceed four (4) amperes. **NOTICE!** Do not connect the remote sense lead to this terminal.

“I” Terminal - Indicator lamp/ignition terminal carries full system voltage. Current draw should not exceed one (1) ampere. Current should not be drawn from this terminal.

Ground Screw – Ground lead ensures alternator is grounded and its use is recommended for optimum performance.

“Remote Sense™” Terminal - Monitors the batteries system voltage at the Batteries or a common distribution point. The Sense terminal on the 33SI, 34SI, 35SI & 36SI is the fourth terminal and is identified with a “remote sense” label on the back cover plate. The 21SI and 22SI Sense terminals will be on either the # 2 Regulator Blade terminal on two terminal regulator models or the “S” Regulator terminal on four terminal regular models. **Notice!** Do not connect anything but the remote sense line to this terminal.

- ◆ If installing a **non-remote sense alternator** in a vehicle that has a remote sense line, disconnect and secure the wire from the battery. **Notice!** Be careful not to ground the leads open end and if it has a fuse it should be deactivated.
- ◆ If installing a **remote sense alternator** in a vehicle that does not have a sense line, **connect a fused (5 Amp) lead** from the Voltage Sense terminal to the Positive (+) Battery terminal or the common distribution point at the starter Solenoid Battery (+) terminal.

Use a **#16 Red Lead Wire**, preferably with a 1/4" ID Convuluted Polyethylene Conduit. Also install a **Standard Inline Fuse Holder with a Protective cap**. Use a low voltage automotive standard blade style fuse, 5 Amp.

- ◆ Only connect the remote sense™ line to the remote sense terminal. **The “R” and “I” Terminals are Not the Remote Sense Terminal!**

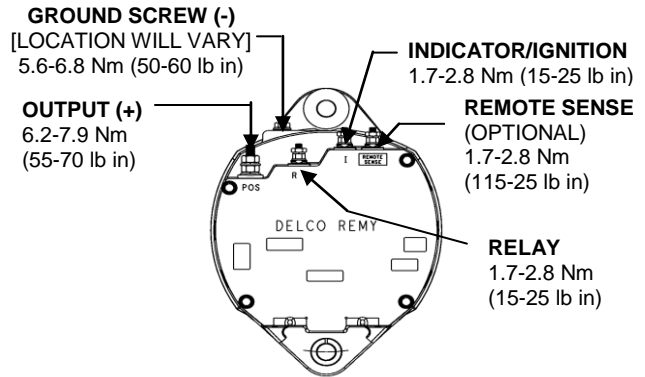

35SI HP™ & 36SI HP™ WITH REMOTE SENSE

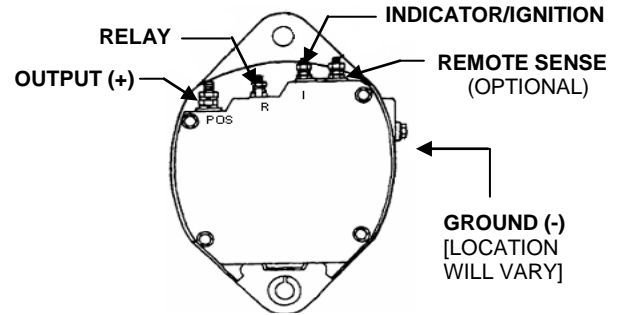

33SI & 34SI REMOTE SENSE

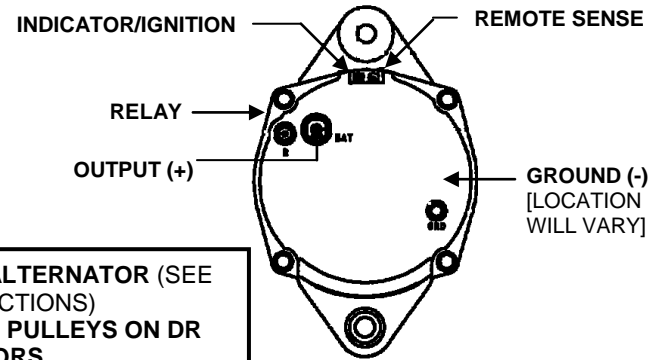

21SI & 22SI REMOTE SENSE 2-TERMINAL REGULATOR

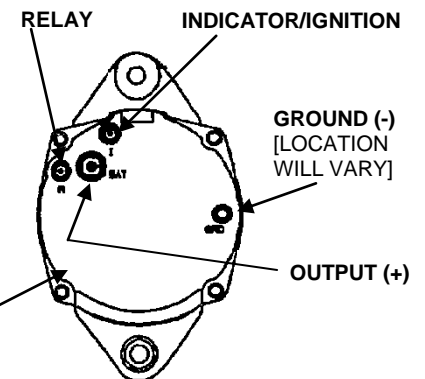

21SI & 22SI NON-REMOTE SENSE™

**USE PULLEY FROM OLD ALTERNATOR (SEE PULLEY INSTRUCTIONS)
KEYS ARE NOT USED ON PULLEYS ON DR ALTERNATORS**

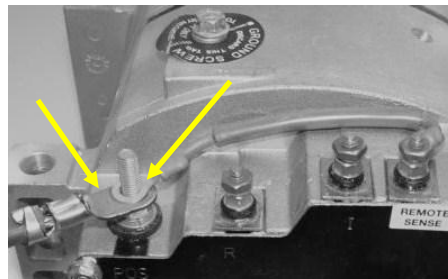

IF USED, PLACE JUMPER- P/N 10532508 - ON TOP OF BATTERY CABLE

33SI, 34SI, 35SI & 36SI - REMOTE SENSE WITH JUMPER

23SI SAME EXCEPT FOR TERMINAL LOCATIONS

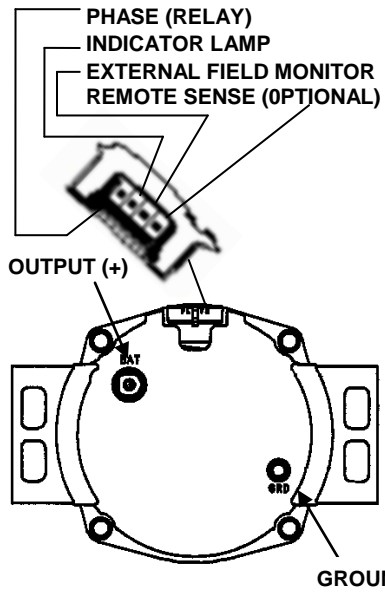

22SI REMOTE SENSE™ 4-TERMINAL REGULATOR

Technical support: USA 800 272 0222, Mexico 01 800 000 7378, Brazil 0800 703 3526, South America 55 11 2106 6510 or visit www.delcoremy.com

NOTICE - Only licensed Remy International, Inc. product and component parts should be used, and the use of other parts or modifications not approved by Remy International, Inc. will void all applicable warranties. The failure to carefully follow these Installation Instructions, set forth above, will void all applicable warranties. DELCO REMY is a registered trademark of General Motors Corporation, licensed to Remy International, Inc. Pendleton, IN 46064.