

INSTALLATION OF 50DN STATOR WITH 1-PIECE INSULATOR

WARNING!!! ALWAYS USE PROPER EYE PROTECTION WHEN PERFORMING ANY MECHANICAL REPAIRS TO A VEHICLE – INCLUDING, BUT NOT LIMITED TO, ANY INSTALLATION AND OR REPAIRS TO THE DELCO REMY ALTERNATORS. FAILURE TO USE PROPER EYE PROTECTION CAN LEAD TO SERIOUS AND PERMANENT EYE DAMAGE.

Only perform the mechanical functions that you are properly qualified to perform. Mechanical repairs that are beyond your technical capabilities should be handled by a professional installation specialist.

1. ENLARGE TERMINAL HOLES IN RECTIFIER FRAME. [See Illustration 1]

- ◆ Carefully maintain hole center location during drilling operation.
- ◆ Drill the three (3) terminal holes to diameter 15.6-15.5 mm (.609”-.612”) using a 15.5 mm or 39/64” drill bit.
- ◆ Carefully remove all burrs and chips after completion of drilling operation.

Notice! The following two part number insulators were replaced with a 1-piece insulator.

- ◆ 1941051 Square washer insulators (3) are not reused.
- ◆ 1952212 “Top-hat” insulators (3) are not reused. The “Top-hat” is replaced with 10502988 insulator washer.

2. ASSEMBLY INSTRUCTIONS. [See Illustration 2]

- ◆ Carefully assemble parts as shown in illustration. New parts in this assembly are noted in **bold font**.

Torque the bottom stator terminal nut to 13.5-16.3 Nm (120-144 lb in) and the top (positive diode plate) stator terminal nut to 19.2-21.5 Nm (170-190 lb in). **DO NOT OVERTIGHTEN TERMINAL NUTS!** Component could be damaged.

ILLUSTRATION 1

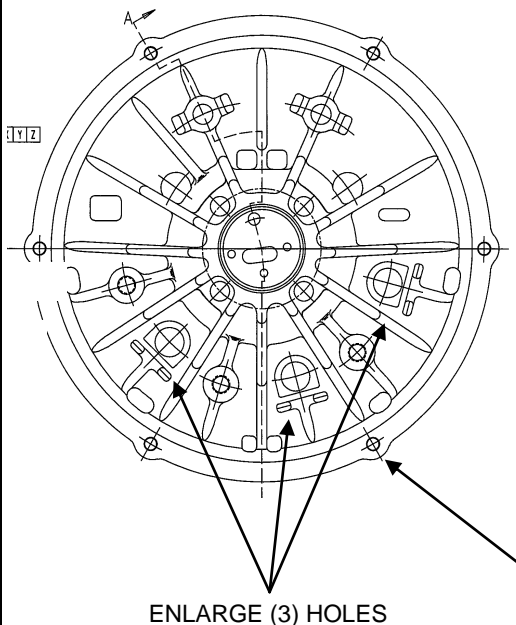
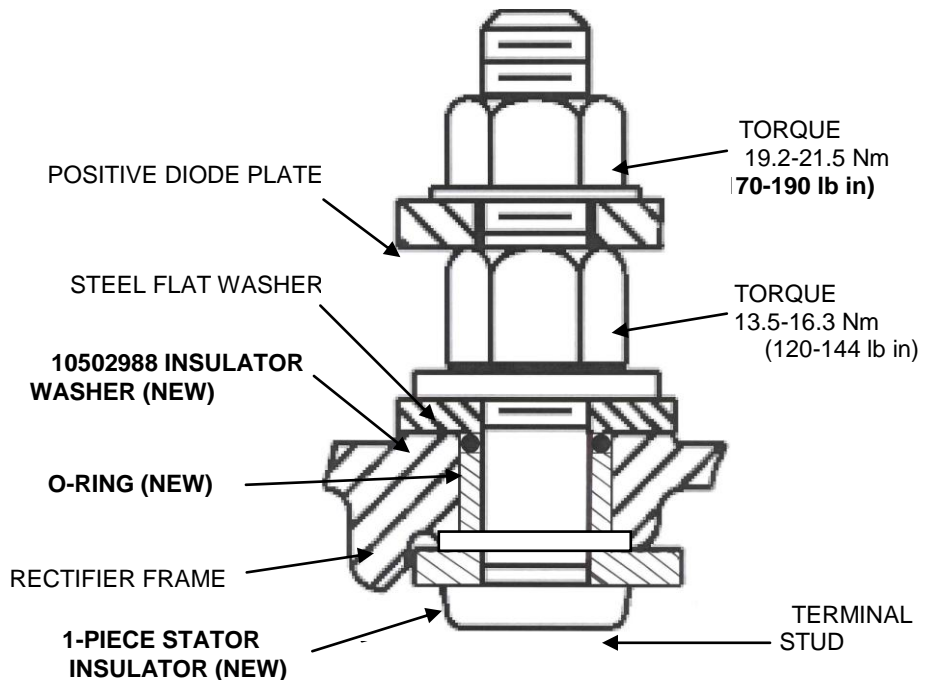

ILLUSTRATION 2



Technical support: USA 800 854 0076, Mexico 01 800 000 7378, Brazil 0800 703 3526, South America 55 11 2106 6510 or visit delcoremy.com

NOTICE - Only licensed Remy International, Inc. product and component parts should be used, and the use of other parts or modifications not approved by Remy International, Inc. will void all applicable warranties. The failure to carefully follow these Installation Instructions, set forth above, will void all applicable warranties. DELCO REMY is a registered trademark of General Motors Corporation, licensed to Remy International, Inc. Pendleton, IN 46064.